



701 S Ridge Avenue, Troy, OH 45374
1-888-4HOBART • www.hobartcorp.com

625A TABLE TOP WRAPPER



STANDARD FEATURES

- Heavy Gauge Aluminum Base
- Aluminum and Stainless Steel Finish
- Stainless Steel Wrapping Surface
- Large Rubber Feet
- Solid State Controlled Hot Rod Cutoff Bar
- Hot Plate Covered with Non-Stick Cover
- Stretch Film – 18" Maximum Width

MODEL

- 625A** Table Top Wrapper

Specifications, Details and Dimensions on Inside and Back.

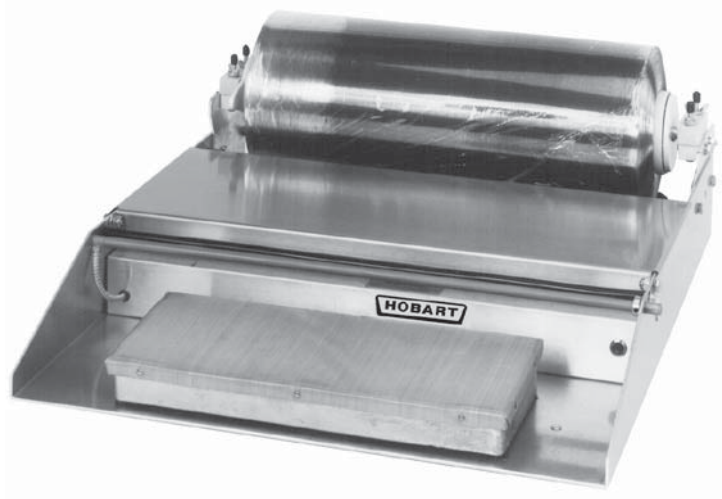

625A TABLE TOP WRAPPER

625A TABLE TOP WRAPPER



701 S Ridge Avenue, Troy, OH 45374
1-888-4HOBART • www.hobartcorp.com

SPECIFICATIONS

DIMENSIONS: 22½" W x 26" D x 8¾" H

ELECTRICAL: 115/60/1, 6.5 amps; CUL approval

HOT PLATE: Generous 6" x 15" size with non-stick cover. Eliminates packages sticking, prevents film residue buildup.

SHIPPING WEIGHT: 28 lbs.

DETAILS AND DIMENSIONS

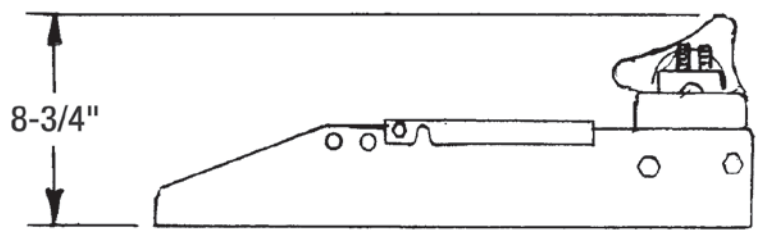
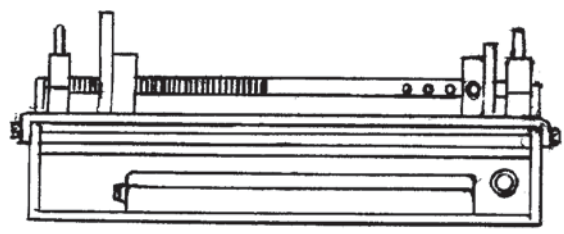
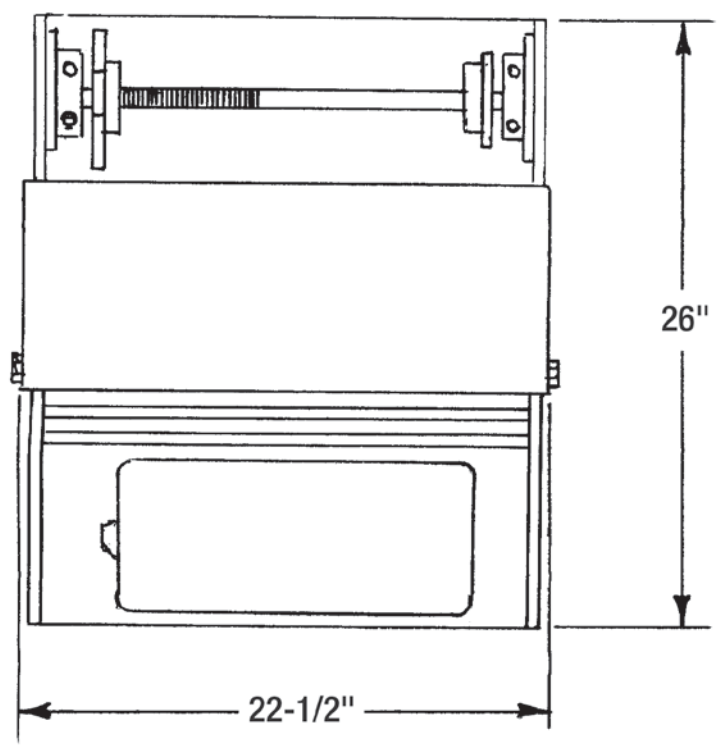

As continued product improvement is a policy of Hobart, specifications are subject to change without notice.