

McCue Corporation

# CartPark 2X

CartPark 2X with or without barriers is the ideal bi-directional cart corral for retailers looking to use motorized cart retrieval equipment. The simple design literally snaps together in minutes and allows entry from either side. Your parking lot looks great because more shopping carts are returned.

**EFFICIENT DESIGN:** Bi-directional configurations are ideal for use with motorized cart retrieval equipment.

**SMART:** Molded side bumpers protect car doors from dings and dents reducing damage claims.

**HIGHLY VISIBLE:** Colorful signage can be seen over any mini-van or SUV, increasing shopping cart return.



Available without Barriers

[www.mccue.com](http://www.mccue.com)



CartPark 2X

McCue Corporation

# CartPark 2X

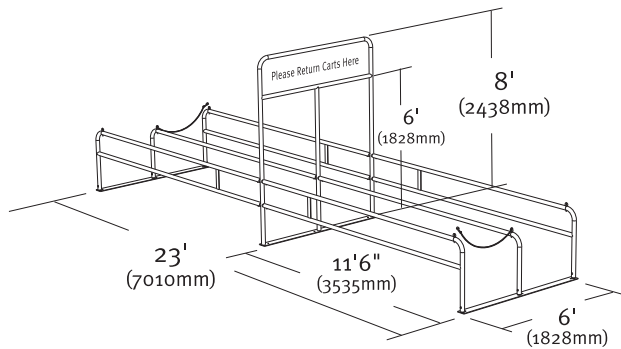

## CartParkStandard 2X

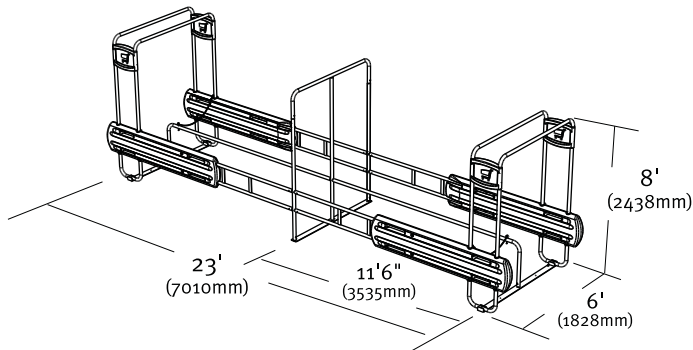
**Cart Width:** 2**Cart Capacity:** 48**Materials:** Galvanized steel pipe**Graphics:** Standard sign includes screened text on two sides "Please Return Carts Here"; custom graphics are available

## CartParkBumper 2X

**Cart Width:** 2**Cart Capacity:** 48**Materials:** Galvanized steel and plastic**Available Colors:** Red, Orange, Forest Green, Blue, Natural**Graphics:** Standard sign includes screened shopping cart graphic; custom graphics are available

**McCue**  
Corporation

McCue Corporation  
35 Congress Street, Suite 150, Salem, MA 01970 USA  
Phone: (800) 800-8503 or (978) 741-8500  
Fax: (978) 741-2542  
Email: [cservices@mccue.com](mailto:cservices@mccue.com)

[www.mccue.com](http://www.mccue.com)

©2010 McCue Corporation. Printed in USA  
Patent 6,298,997.

## Placing an order:

There are five easy ways to order:

- 1) E-mail your order: [cservices@mccue.com](mailto:cservices@mccue.com)
- 2) Phone our toll-free number: (800) 800-8503 or call (978) 741-2542
- 3) FAX in your order: (978) 741-2542
- 4) Mail in your purchase order
- 5) Online at [www.mccue.com](http://www.mccue.com)