



701 S Ridge Avenue, Troy, OH 45374  
 1-888-4HOBART • www.hobartcorp.com

**403  
 TENDERIZER**



**ACCESSORY KNIVES**

- Strip Cutter Knives – cut flank steak, sirloin, chicken breast or pork for stir fry or fajitas; strip cut cooked ham, turkey and cheese for chef salads or garnishes. Each comes standard with a storage holder. Available in three sizes:
  - Extra Wide (3/4")
  - Wide (5/8")
  - Narrow (3/16")
- Star Knives – rollers use an 11 tooth pointed star blade. This produces a lighter, less dense tenderizing cut for more delicate meats.
- Chrome-plated lift-out finish (acceptable to USDA) is available at extra cost.

**MODEL**

- 403-1 Tenderizer – Tenderizer with interlocks supplied with Knit-Knife stainless steel blades that cut meat and, at the same time, knit it so firmly together that it will cook as one solid steak.

Specifications, Details and Dimensions on Reverse Side.



**SOLUTIONS / BENEFITS**

**Lower Profile with Cut-Outs**

- Meat can be inserted closer to the blades; operation is easier and faster

**Plastic Guides Inside Guard**

- Guides meat into knives, reduces unintentional folding

**Larger Reinforced Magnet Mounting**

- Reduces breakage

**Translucent Guard**

- Allows operator to view product processing

**Variety of Knives Available**

- Versatility with meats and cheese

**Interlock Systems**

- Won't feed if guard or motor housing not in place

**Lift Out Unit Frame**

- Ease of cleaning, ease of use

**Burnished Aluminum Housing**

- Ease of cleaning
- Designed to accommodate pan for holding prepped product



# 403 TENDERIZER

**HOBART**

 701 S Ridge Avenue, Troy, OH 45374  
 1-888-4HOBART • www.hobartcorp.com

## SPECIFICATIONS

**MOTOR:** ½ H.P., totally-enclosed, fan-cooled, single-phase, capacitor-start, induction-run type.

**ELECTRICAL:** Furnished in electrical specification of 115/60/1, UL Listed. Also available in 220/60/1 and 220-240/50/1 – not submitted for UL Listing.

**SWITCH:** Manual 2 pole type.

**SAFETY SYSTEM:** (1) Safety interlocked on translucent guard and motor housing. Remote electro-magnetic sensing switches detect if guard or motor housing are not in place and prevent feed. Switches cannot be mechanically blocked.

(2) Integral chute in translucent guard keeps hands at safe distance from tenderizing knives. (3) Pilot light warns when machine switch is ON even though machine is inoperable because translucent guard or motor housing is not in place.

**CORD & PLUG:** 6-foot, 3-wire cord and plug for grounding. Plug not furnished on export models.

**TRANSMISSION:** Hardened Steel Worm drives forged bronze worm gear in fluid grease bath. Counter-rotation of tenderizing knives obtained through spur gears mounted on hardened and ground alloy steel stub shafts. Gears sealed in cast transmission case. Motor, Worm and Gear Case are an integral unit for precision mount-in and easy cleaning. Bath lubricated needle and ball anti-friction bearings in transmission case. Grease-packed ball bearings in motor.

**BLADES & SHAFT:** Blades and shafts are made of heavy duty stainless steel.

**CLEANING COMBS:** Satin finish stainless steel, easily removable. Combs guide meat between rollers, automatically prevents any accumulation of meat between knives.

**LIFT OUT UNIT FRAME:** Cast aluminum with special bearings. Contains set of stainless steel shafts and cleaning combs hinged to swing free from blades for unit cleaning - combs can be removed easily. Automatic unit lock holds assembly in place.

**HOUSING:** Housing consists of cast aluminum gear case and motor housing and high impact plastic translucent guard. Lift out unit nested by cast aluminum support on stainless steel tie bars and shield. Unit designed to be quickly and easily cleaned.

**FINISH:** Burnished aluminum and translucent plastic.

**WEIGHT & DIMENSIONS:** Net wt. 56 lbs., shipping wt. 66 lbs. Height 21<sup>7</sup>/<sub>16</sub>" , counter space 10<sup>1</sup>/<sub>2</sub>" x 19<sup>5</sup>/<sub>8</sub>". Feed throat opening 1<sup>3</sup>/<sub>8</sub>" x 7<sup>7</sup>/<sub>8</sub>".

**STANDARD EQUIPMENT:** Cleaning fork.

**OPTIONAL KNIVES:**

- Knit
- Star
- Strip Cutter - 3 sizes

**WARRANTY:** Unit has full one-year warranty on parts, labor and mileage against manufacturer's defects. Service contracts are available.

## DETAILS AND DIMENSIONS

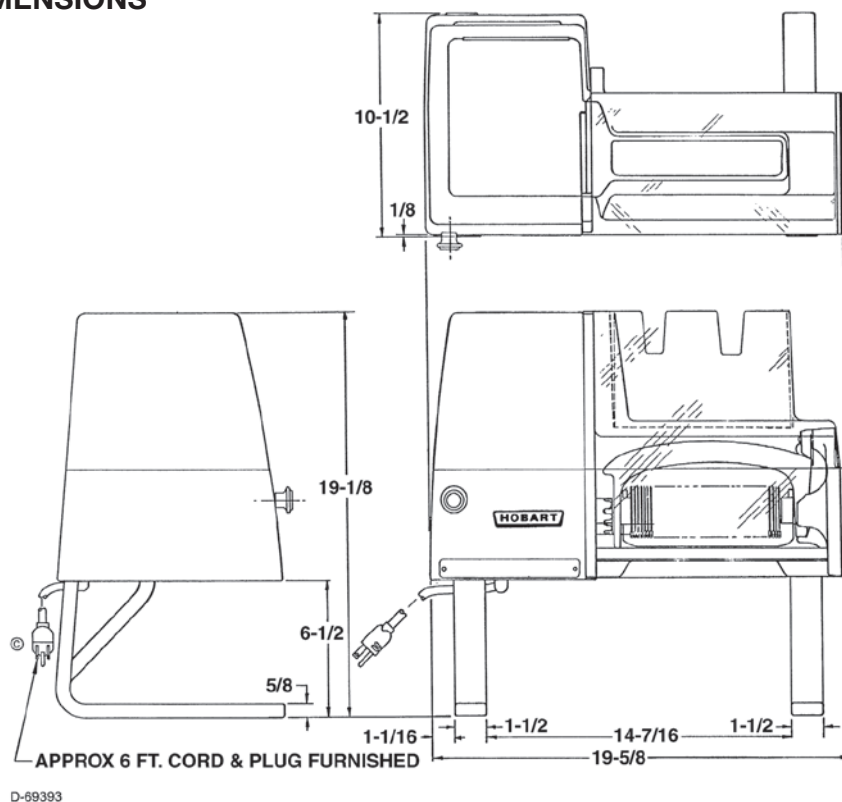

As continued product improvement is a policy of Hobart, specifications are subject to change without notice.