



701 S Ridge Avenue, Troy, OH 45374  
 1-888-4HOBART • www.hobartcorp.com

# HWS-4-C HAND-WRAP STATION



## STANDARD FEATURES

- Flexible Set-Up
- Easy to Load Film
- 20" Film Capacity
- Fingertip Film Selection
- Low Temperature Film Cut-Off System
- Angled Hot Plate
- Stainless Steel Element
- Heavy-Duty 300 Series Stainless Steel Stand Assembly
- Open Scale Area
- Operates in All Ambient Temperatures
- 12 Hour Timer for Hot Plate and Cut-off Rod to Save Electric
- Convenient Outlet Provided for Scale/Printer Power

## ACCESSORIES

- HWS-WRAPAD** – Hand Wrap Station Aid
- ACCESS-HWSKIT** – HWS Post Assembly Plate for Printer, USB Cable and Power Cable for Control Panel
- QUANTMP-HWSPST** – HWS Single Printer Post, Bracket and Scale Support
- POST-LGSP** – Post Assembly for Library Look Up
- LIBRARY-SUPPRT**



## MODEL

- HWS-4-C – Hand-Wrap Station

Specifications, Details and Dimensions on Inside and Back.



**HLXP-1 Hand-Wrap System with Color Touch Screen**



**Access Scale Hand-Wrap System with Color Touch Screen**



**Quantum Scale System Hand-Wrap Station**

**HWS-4-C HAND-WRAP STATION**

# HWS-4-C HAND-WRAP STATION



701 S Ridge Avenue, Troy, OH 45374  
1-888-4HOBART • www.hobartcorp.com

## SPECIFICATIONS

**CONSTRUCTION:** Heavy-duty stainless steel frame. 36<sup>1</sup>/<sub>4</sub>" H x 27"W x 27"D. Shelf 12<sup>5</sup>/<sub>8</sub>"W x 28"D.

**HOT PLATE:** 15" W x 6"D.

**FILM HOLDERS:** Two roll film selector. Capacity 10" diameter x 20" maximum.

**ELECTRICAL:** 120 Volts, 60 Hertz, single phase, 8.5 Amps.

**SHIPPING WEIGHT:** HWS – approximately 90 lbs.; POST-LGSP – 4 lbs.; HWS-WRAPAD – 8 lbs.

**NOTE: SCALE, PRINTER AND POST MUST BE ORDERED SEPARATELY.**

## DETAILS AND DIMENSIONS

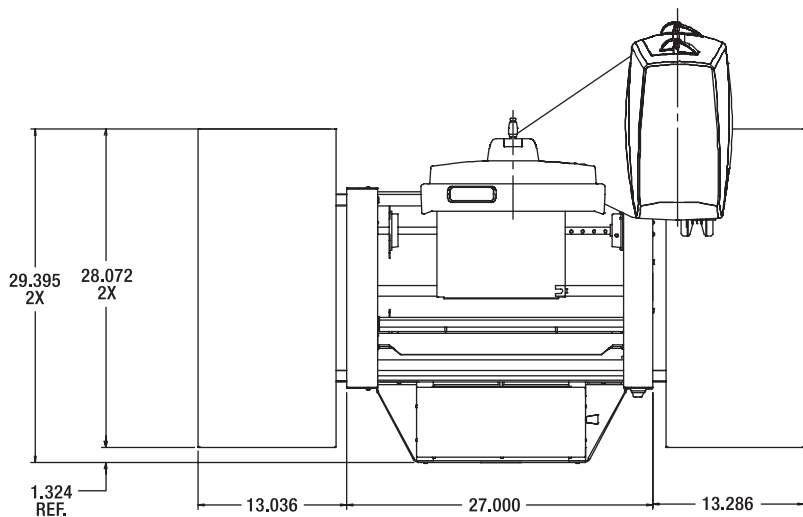

Access Hand-Wrap System

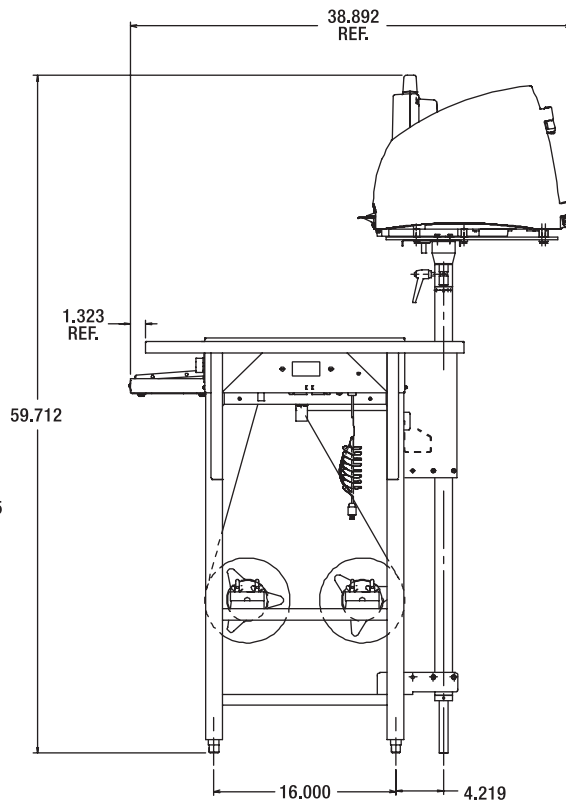
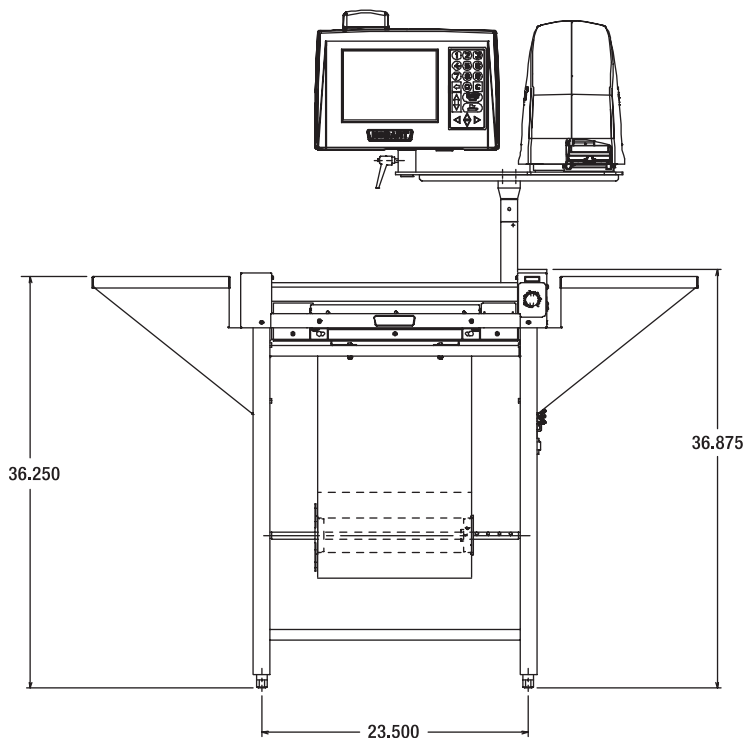



701 S Ridge Avenue, Troy, OH 45374  
1-888-4HOBART • www.hobartcorp.com

GED-1M30

# HWS-4-C HAND-WRAP STATION

## DETAILS AND DIMENSIONS

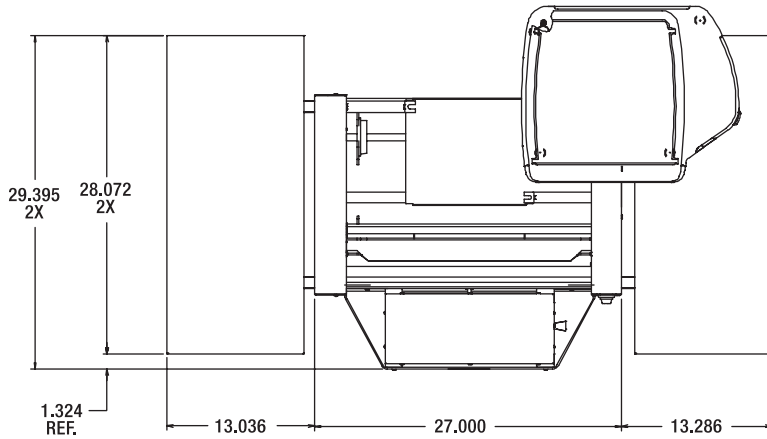

Quantum Hand-Wrap System

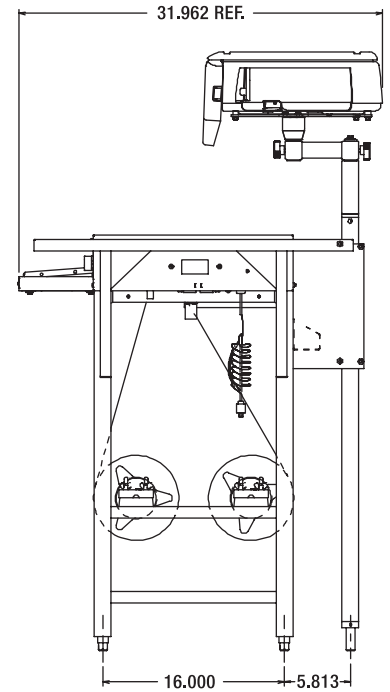
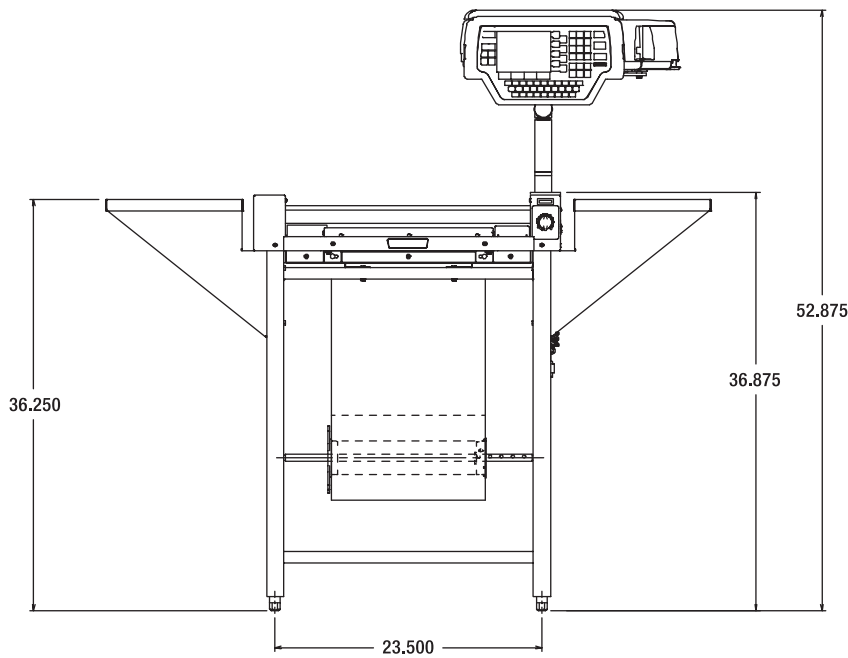

# HWS-4-C HAND-WRAP STATION



701 S Ridge Avenue, Troy, OH 45374  
1-888-4HOBART • www.hobartcorp.com

## DETAILS AND DIMENSIONS

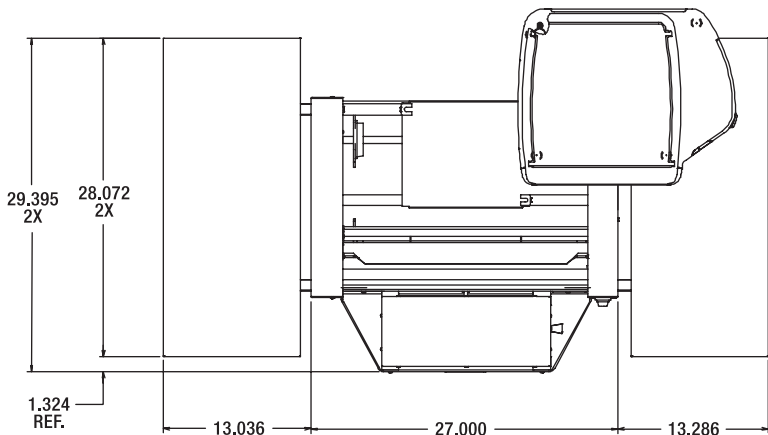

HLXP-1 Hand-Wrap System

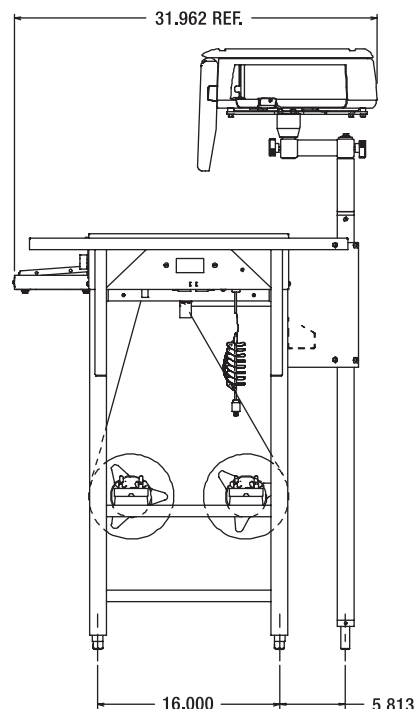
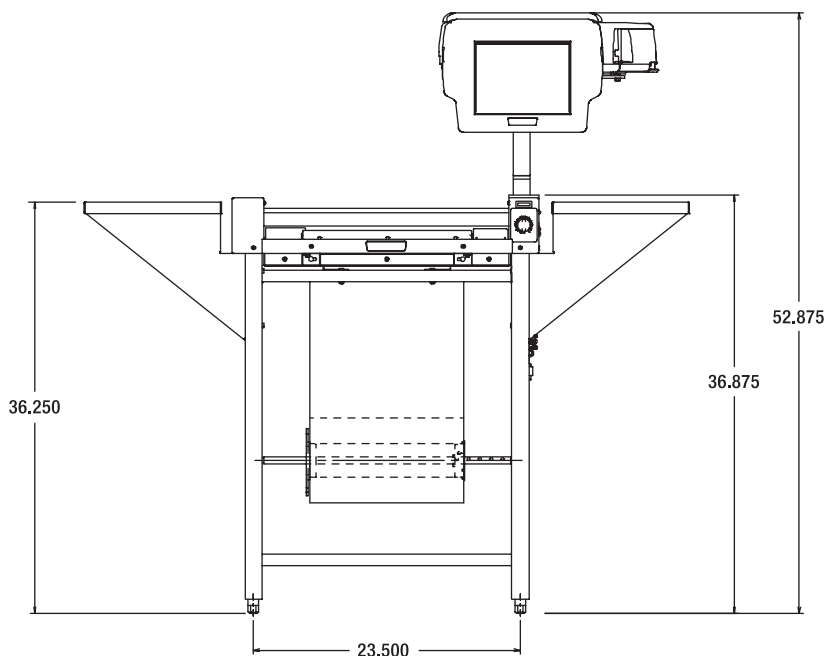

As continued product improvement is a policy of Hobart, specifications are subject to change without notice.