



Known for Reliability

Since 1921

The Biro Model AFMG-52 (Auto-Feed Mixer-Grinder) is the ideal workhorse for large supermarket meat rooms and medium sized processors and HRI plants. Its 7.5 hp (5.6 kW) motor (or optional 10 hp, 7.5 kW motor) provides a production output of up to 100 lbs. (45.5 kg) per minute to give you the productivity you need.

The heavy duty roller chain auger drive system with tapered roller bearing journal box is separate from the heavy duty mixer motor interface gear drive system. This more efficient design transfers maximum torque power to the auger. The heavy duty stainless steel 200 lb. (91 kg) hopper and frame resist corrosion and damage, even in an environment of harsh cleaners. Your mixer grinder lasts longer and gives you more return on your investment. Power, durability, and low maintenance make the Biro Model AFMG-52 Auto-Feed Mixer-Grinder a meat room workhorse.



MODEL AFMG-52
AUTO-FEED MIXER-GRINDER
Shown with Optional (NC)
Right Hand 35 ° Hopper Feed Inlet

1/8" (3.5 mm)



3/8" (9.0 mm)



AFMG-52

MODEL AFMG-52 SPECIFICATIONS

Model: AFMG-52 Auto-Feed Mixer-Grinder

Construction: Heavy duty stainless steel hopper, lid, paddle, frame and legs. Cast iron hot tin dipped Size 52 bowl, ring and auger.

Motors: TEFC = Totally Enclosed Fan Cooled

MOTOR	HP	KW	TYPE	VOLTS	AMPS	CYCLE	PH	STATUS
AUGER	7.5	5.6	TEFC	208-230/460	24-22/11	60	3	STD
MIXER	1.75	1.3	TEFC	208-230/460	5.7-5.2/2.6	60	3	STD
AUGER	10	7.5	TEFC	208-230/460	31-28/14	60	3	EC
AUGER	7.5	5.6	TEFC	575	8.8	60	3	EC
MIXER	1.75	1.3	TEFC	575	2.4	60	3	EC
AUGER	10	7.5	TEFC	575	11	60	3	EC
AUGER	7.5	5.6	TEFC	220/380-415	22/12.7-11.6	50	3	STD
MIXER	1.75	1.3	TEFC	220/380-415	5.9/3.4-3.1	50	3	STD
AUGER	10	7.5	TEFC	220/380/415	28/16.2/14	50	3	EC

EC = Extra Cost NC = No Charge STD = Standard

Switch: Watertight magnetic with thermal overload and under voltage protection.

Power Cord: 12' #10 GA - 4 strand cord with plug 7.5 hp, U.S.
 12' #10 GA - 4 strand cord no plug 7.5 hp International,
 12' #8 GA - 4 strand cord with plug 10hp U.S.,
 12' #8 GA - 4 strand cord no plug 10hp International.

Hopper Capacity: Hopper: 200 lbs. (91 kg).

A 400 lb. (182 kg) is also available, see AFMG-52-4.

Grinding Capacity: Output - up to 100 lbs. (45.5 kg) per min.

Drive System: Auger: Single reduction (35 pitch - 4 row) roller chain drive with tapered roller bearings. See option EC (poly) belt auger drive system.

Mixer: Heavy duty motor interface gear drive system.

Safety: Magnetic safety interlock on hopper lid.

Standard Features: Stainless steel 2nd grind paddle with center arms • 5" Dia. total lock swivel casters with anti-microbial wheels • spurt guard • extra rod for front, left or right side opening lid • power cord (see above) • ring wrench • bowl nut wrench • two shear pins with screws • receptacle for electric footswitch • operating and safety manual.

Options (NC): Size 52 right hand 35° hopper feed inlet (see drawing).

Options (EC): Size 52 plate and knife • single-reduction "Eagle" self-centering, no stretch, no lubrication, poly belt auger drive • electrical or pneumatic footswitch • accessory cleaning and storage rack • extra long stainless steel legs (33"(838 mm) to 42"(1067 mm)) from floor to bowl center • size 52 left hand 35° hopper feed inlet • connections for tandem operations • 10hp (7.5 kw) auger motor • stainless steel bowl, ring, and auger (enterprise or unger style).

Certification: U.S.D.A., U.L., N.S.F., C.S.A.

Weight: Uncrated: 759 lbs. (343 kg) approximate.
 Carton Packed: 863 lbs. (391 kg) approximate.
 Wood crated: 962 lbs. (436 kg) approximate.

Dims Crated: L=50" (1270 mm), W=36" (914.4 mm),
 H=66" (1676 mm)

BIRO MANUFACTURING COMPANY
 1114 WEST MAIN STREET
 MARBLEHEAD, OH 43440-2099 U.S.A.

Phone: (419) 798-4451 <http://www.birosaw.com>
 Fax: (419) 798-9106 sales@birosaw.com

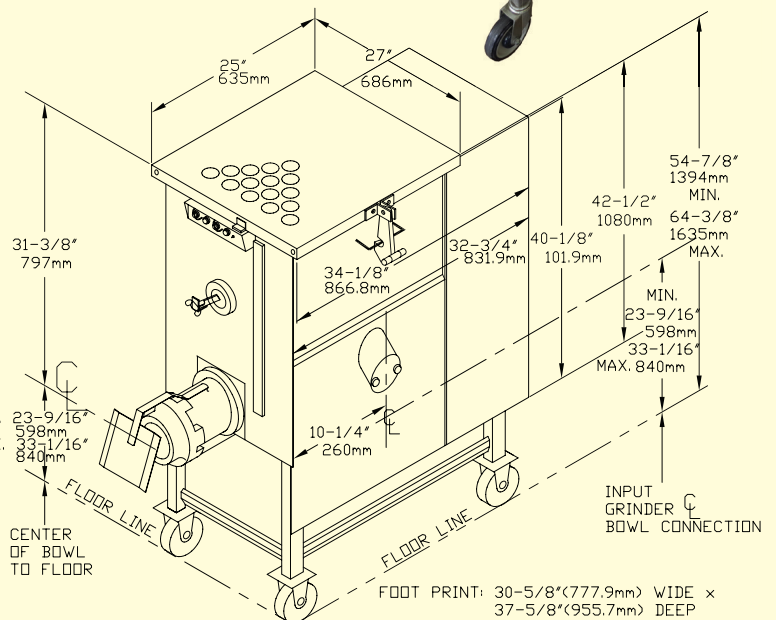
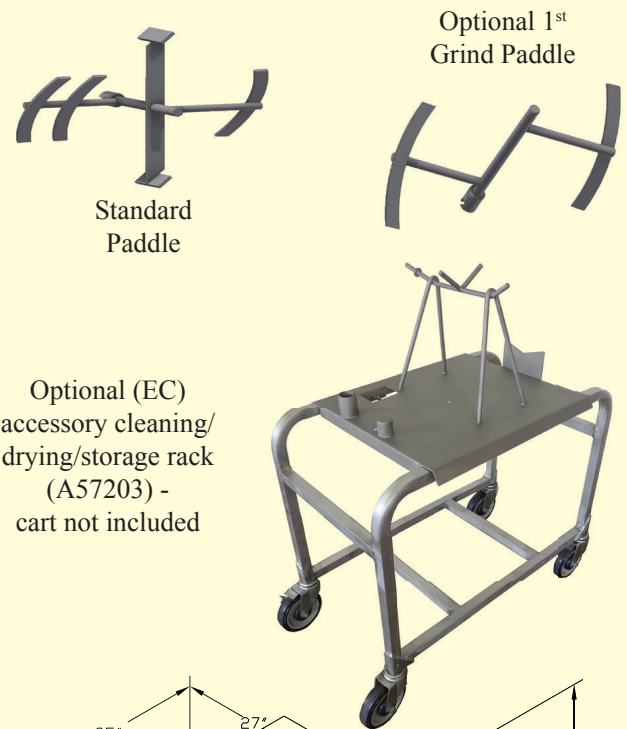

Above shows optional, (NC) right hand 35° hopper feed inlet

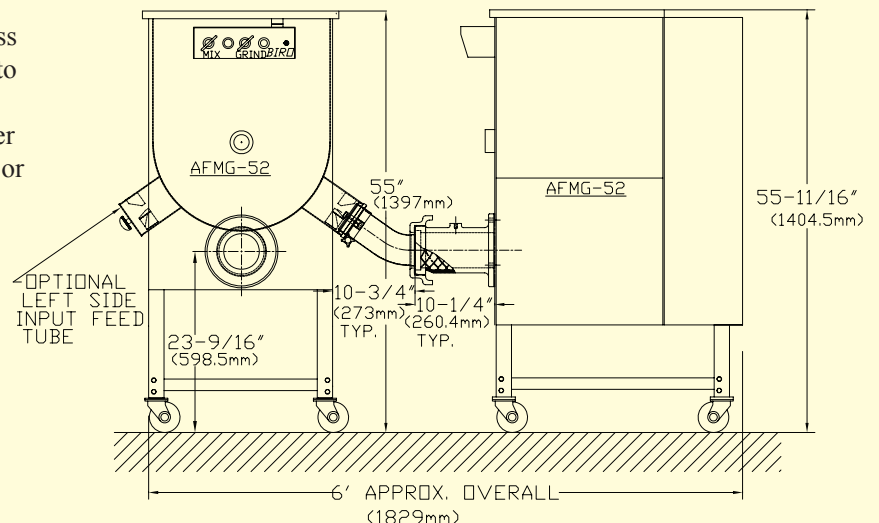

AFMG-52 to AFMG-52 Tandem System

All specifications contained herein are subject to change without notification.

ITEM NO.: LIT-AFMG-52-231
 FORM NO.: AFMG-52-231-6-14-12-B

Service is available from locations worldwide