

RLNIE End Case

RLNIE Back-to-Back



RLNI, RLNIE

The Ultimate Reach-In Merchandising Solution
for Frozen Food Applications

- Available with Hussmann “Innovator”,
“Innovator II” or “Innovator III” Glass Doors.

CED 1G27, 1G28, 1G30, 1G31

Husmann Ultimate Reach-In Merchandising Solution for Frozen Food Applications

RLNI - Back-to-Back Reach-In
RLNIE - Back-to-Back Reach-In End Case
 Available with 2, 3, 4, and 5 doors.

RLNI
RLNIE

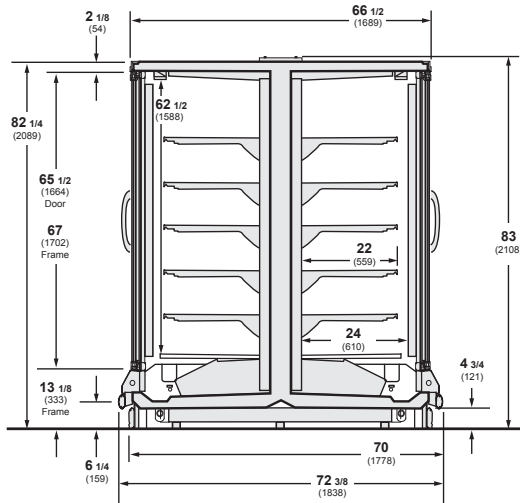

Plan Views

RLNI

Notes:
 Overall case length without ends or partitions.

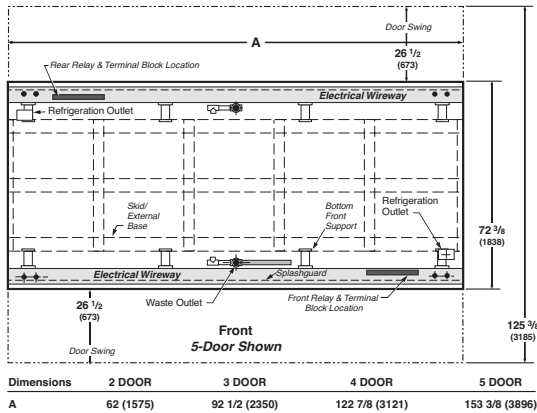

Dimensions

Dimensions	2 DOOR	3 DOOR	4 DOOR	5 DOOR
A	62 (1575)	92 1/2 (2350)	122 7/8 (3121)	153 3/8 (3896)

Notes:
 Overall case length without ends or partitions. Contact your sales representative for information on possible availability of additional case lengths.

RLNIE

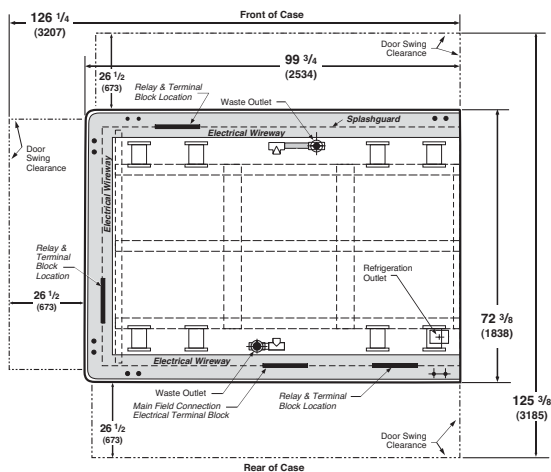

Less Floor Space Required.

Installing standard reach-ins back to back requires about 88-inch of floor space, from bumper to bumper. The RLNI is 72-inch wide, bumper to bumper, saving about 16-inch.

Reduced Installation Labor.

Because the RLNI and the RLNIE are unitized, there is no need to set and line up two rows of back-to-back cases or add separate end cases.

Perfect for Wide Island Replacement.

If you want to increase frozen food product facing, this is an ideal way to do it. Most wide islands are about 82-inch wide. You can replace them with the 72-inch RLNI and watch your product facing skyrocket.

Same Product Capacity as Standard Reach-Ins.

The product capacity per door in the RLNI is identical to the capacity of the standard depth RL. Maximum shelf depth of 22-inch is the same in both cases.

Greater Energy Efficiency.

Innovator III doors are 43% more efficient than Innovator doors and provide 13% total case energy savings compared to a case with Innovator doors. Innovator III is a lower energy heated door that can be used in all climate conditions. For even more energy savings, Innovator II is a no-heat door that offers 32% case energy savings.

Standard LED Lighting.

EcoShine II LED lighting is standard. The lights are optimized for uniform brightness and substantially lower energy costs compared to fluorescents.

DOE 2017 Energy Efficiency Compliant Husmann refrigerated merchandisers configured for sale for use in the United States meet or surpass the requirements of the DOE 2017 energy efficiency standards.

NOTE: These merchandisers are designed for use in stores when temperature and humidity do not exceed 75°F and 55% R.H.

NOTE: We reserve the right to change or revise specifications and product design in connection with any feature of our products. Such changes do not entitle the buyer to corresponding changes, improvements, additions, or replacements for equipment previously sold or shipped.

For additional resources, contact your representative or visit www.husmann.com.

Note

Use Husmann's technical data sheets to get precise dimensions for all store layout purposes.

HUSMANN®

Husmann Corporation
 12999 St. Charles Rock Rd.
 Bridgeton, MO 63044-2483
 Ph: 314.291.2000

www.husmann.com