

**HUSSMANN®**

---

Specialty



*Q-Series Family*

**Q3-MC, Q3-FC**

Multi-Deck Service Merchandiser  
with Curved Glass for Meat and Seafood Applications

## Hussmann Q-Series Multi-Deck Service Merchandiser with Curved Glass for Meat and Seafood Applications

### Q3-MC, Q3-FC



#### Quality Fit and Finish

Designed for ease of installation. Simplified glass adjustment has special alignment design to assure fit. Does not require unsightly joint trim. Matches sleek design elements of the Q-Series family.



**Merchandising Flair**  
Optimized visibility - Full view of display deck. Standard lighting produces a balanced spectrum of light with superior color definition and low glare.



**Ergonomics**  
Large rear door opening and angled back improves product access.

**Product Shelf Life**  
Dual refrigerated systems to reduce product dehydration and shrink.



**Merchandising Flexibility**  
Adjustable deep deck with conduction coil for meat.

**Remote Lengths: 4', 6', 8', and 12'**  
**Wedges: 22.5° inside and outside wedges**

**Q3-MC Service Meat**

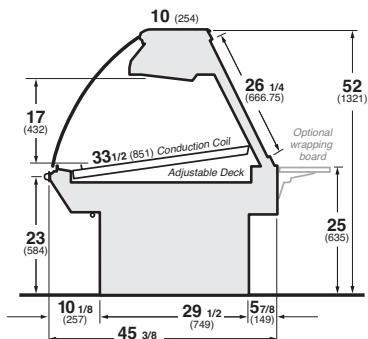

**Q3-FC Service Fish**

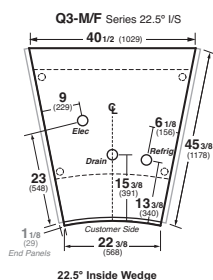
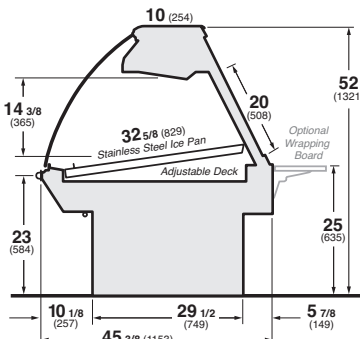

22.5° Inside Wedge

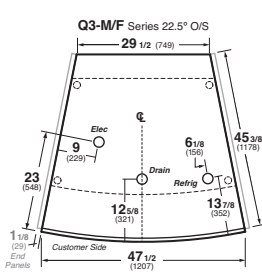

22.5° Outside Wedge

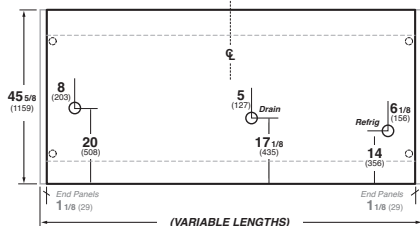

**Notes:**  
Contact your sales representative for information on possible availability of additional case lengths.

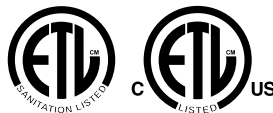

**Intertek Intertek**

**Note.**

Use Hussmann's technical data sheets to get precise dimensions for all store layout purposes.

### Features and Benefits:

- Tempered, lift-up curved front clear glass
- Large clear glass sliding rear doors
- Gravity/conduction coil (Meat)
- Gravity coil, ice pans with stops (Fish)
- Stainless steel interior pans
- Adjustable deck for flexible merchandising
- Adjustable stainless steel legs
- Stainless steel top cover
- Black matrix on the glass to cover the coil
- Black powder-coated coil cover
- Solar digital thermometer
- Front glass air sweep (Meat)
- Front glass heated air sweep (Fish)
- Double row LED canopy lighting †
- Electronic ballast
- Thermostat and suction stop installed
- Black vinyl cart bumper
- Please reference color chart for choice of standard Hussmann paint and finish options ([www.hussmann.com](http://www.hussmann.com))

### Options Include:

- Coil corrosion protective coating (Q3-FC)
- LED ledge lights †
- Tempered, non-glare, lift-up curved front clear glass
- Automatic or manual water flush (reduces the need for manual case cleaning)
- Corian®, granite or other solid surface front and/or top ledge (NSF approved material)
- Mirrored rear doors
- Thermoplastic wrapping boards with adjustable riser
- View or solid ends
- Mirror bright stainless steel inside end panels
- Stainless steel pedestals
- Top mounted scale stand extensions with dedicated scale outlet and Cat 5 scale connections
- Liquid line shut-off hand valve
- 15 amp GFCI duplex outlet
- Custom trim and decor
- Custom lengths and options\* (consult your Hussmann sales representative)
- Special exterior finishes\* (consult your Hussmann sales representative)

### Additional Information:

- Q-Series Entire Family: **Q-Series Family**
- Single-Deck Service Deli Curved Glass: **Q1-DC**
- Single-Deck Self-Service Deli: **Q1-SS**
- Service Hot Curved Glass: **Q-HC**
- Multi-Deck Service Bakery Curved Glass: **Q3-BC**
- Multi-Deck Service Deli Curved Glass: **Q3-DC**
- Multi-Deck Self-Service Deli: **Q3-SS or Q4-SS**
- Multi-Deck Self-Service with Service Top Deli: **Q3-SP**

**DOE 2017 Energy Efficiency Compliant**

Hussmann refrigerated merchandisers configured for sale for use in the United States meet or surpass the requirements of the DOE 2017 energy efficiency standards.

\* Some optional features may need to be certified by UL, NSF, and/or other 3rd party certification agencies. Contact Hussmann for verification or questions for availability.

† Only lighting configurations that are compliant with the U.S. Dept. of Energy (DOE) 2017 regulation are available for sale for use in the U.S.A.

NOTE: These merchandisers are designed for use in stores when temperature and humidity do not exceed 75°F and 55% R.H. We reserve the right to change or revise specifications and product design in connection with any feature of our products. Such changes do not entitle the buyer to corresponding changes, improvements, additions, or replacements for equipment previously sold or shipped.

For additional resources, contact your representative or visit [www.hussmann.com](http://www.hussmann.com).

**Hussmann Specialty**  
13770 Ramona Avenue  
Chino, California 91710-5423  
Ph: 1-800.395.9229

[www.hussmann.com](http://www.hussmann.com)