



C2X-XGE

C2X-XEP, C2X-XGE, C2X-XGEP,
C2X-XLGE, C2X-XLE, C2X-XLEP,
C2X-XLGEP

Excel Multi-Deck Convertible Merchandisers
for All Medium Temperature Applications

Husmann Excel Multi-Deck Convertible Merchandisers for Prepared Sandwiches, Salads and Pizza Applications

C2X-XEP
C2X-XLE

C2X-XGE
C2X-XLEP

C2X-XGEP
C2X-XLGE

C2X-XLGE

E = Energy Efficient Coil
EP = E Plus, Extra High Efficiency Coil
L = Low Front
G = Glass Front

Extra-height (55³/₄" models available.
Available in 8' and 12' lengths. Contact your sales rep for information on possible availability of additional case lengths.

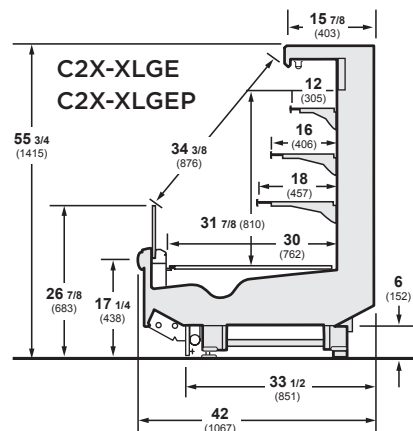
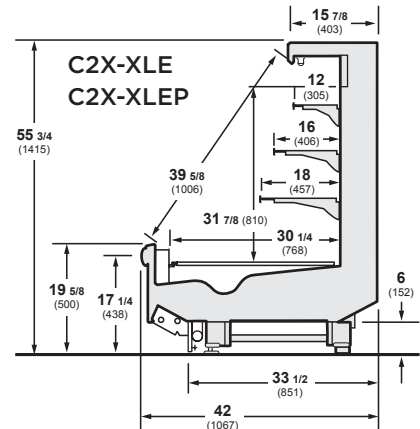
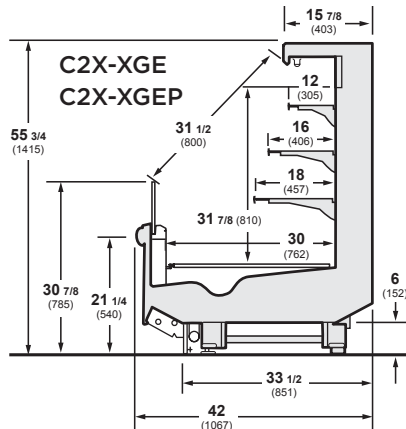
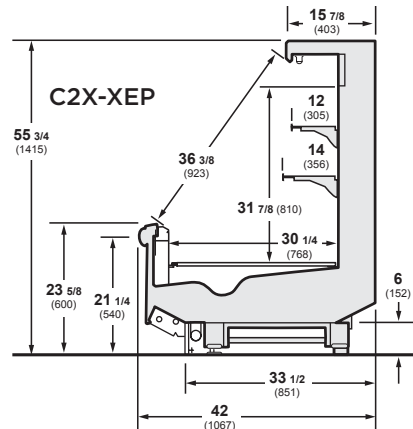

Plan View

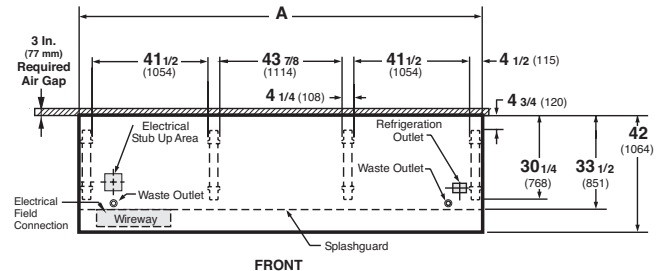

Dimensions	8 FT	12 FT
A	96 3/8 (2448)	144 1/2 (3670)

*C2X-XEP is not available in 12-foot length.
**C2X-XGEP is not available in 8-foot length.

Notes:
Case-to-case electrical connections are made in front of splashguard.
Overall case length without ends or partitions.

Note

Use Husmann's technical data sheets to get precise dimensions for all store layout purposes.

Superior Merchandising.

The C2X-X family (55-³/₄" tall) provides about 7 additional inches of height compared to the C2X (48-¹/₂" tall) for additional merchandising capacity. Ideal for grab-n-go meals or other high margin prepared food selections such as sandwiches, prepared salads, pizza, etc.

Lower Energy Costs.

All Excel C2X-X cases come with energy efficient "E" coils or super efficient E-Plus coils as standard.

Superior Shelf Life.

Modular coils and off-time defrost work to reduce thermal shock and stabilize product temperatures.



Husmann refrigerated merchandisers configured for sale for use in the United States meet or surpass the requirements of the DOE 2017 energy efficiency standards.

Lower Labor Costs.

Labor saving features include greater clearance under the case, easy-to-clean bathtub bottom with no coil in the bottom of the case, easier raceway access, 2-ft honeycomb sections and more.

Superior Reliability.

Our five-year modular coil warranty is the best available. Pre-set adjustable expansion valves are designed to hold optimal temperatures.

NOTE: These merchandisers are designed for use in stores when temperature and humidity do not exceed 75°F and 55% R.H.

NOTE: We reserve the right to change or revise specifications and product design in connection with any feature of our products. Such changes do not entitle the buyer to corresponding changes, improvements, additions, or replacements for equipment previously sold or shipped.

For additional resources, contact your representative or visit www.husmann.com.

HUSMANN®

Husmann Corporation
12999 St. Charles Rock Rd.
Bridgeton, MO 63044-2483
Ph: 314.291.2000

www.husmann.com