

PROJECT	QUANTITY	ITEM NO
---------	----------	---------

# Rotisserie



**SCR 8** 8-spit  
Countertop

**SCR 16** 16-spit  
Stacked



SCR 8 countertop  
8-spit rotisserie



SCR 16 stacked  
16-spit rotisserie

The sight, smell and taste of rotisserie chicken can add significant impact and sales to your store. With such a powerful appeal to the senses, choosing your equipment is critical.

But why choose Henny Penny rotisseries? You'll get *more* of those delicious whole birds, ribs, pork roasts and other center-of-the plate items every day because the Henny Penny rotisserie simply cooks faster.

**THERMA-VEC® Even Heat** Process combines cross-flow convection cooking with radiant heat. The result is thorough, even cooking with uniform browning in a lot less time than other rotisseries.

The single cabinet SCR 8 countertop rotisserie saves on floor space while cooking up to 40 whole birds in a single load! The stacked SCR 16 doubles that production—a massive 80 whole birds per load—from the same footprint, while providing the flexibility of two independently operated rotisseries.

With 9 available cook cycles (per cabinet) and choice of browning level, chefs can dial up just the right color and crispness for seasoned and marinated meats, fish and poultry... every time!

Easy-to-use controls feature LED displays and probe cooking. Units can be configured with various features on control side and customer side.

Spits, rotor disks, drive tube and drip trays remove easily for cleaning and are made with coated surfaces for easy cleanup.

Henny Penny offers a host of accessories including mobile loading stands, product display units, and merchandising bases that increase productivity and impulse sales.

## Standard Features

- **THERMA-VEC® Even Heat** Process cooks full loads quickly and evenly:
  - Gentle, cross-flow convection for even cooking throughout cabinet
  - Radiant heat for uniform browning and crisp texture
- Easy-to-use touch key controls with large LED simultaneous time and temperature display
- 9 programmable cook cycles for each cabinet, 18 total for SCR 16
- Programmable browning and texture control
- Food temperature probe
- Tempered clear glass doors with black matrix shaded borders
- Rotation stops automatically when doors open
- Spit rotation switch for easy loading
- Interchangeable spits, racks or baskets
- Simple three-piece drive tube and rotor assembly
- Drive assembly, drip trays and drain pans disassemble easily for quick cleanup
- Coated spits and interiors for easy cleaning
- Stainless steel construction for easy cleaning and long life

## Please choose configuration

- 8 or  16 **angled spits** OR
- 8 or  16 **piercing spits** OR
- 8 or  16 **solid bottom baskets** OR
- 8 or  16 **wire baskets**
- Cabinet style
- Solid back**
- Pass-through
  - Customer side door handle
    - with  without
  - Customer side rotation switch
    - with  without
- 4 casters 3 in (76 mm)
- SCR 16 low profile caster mounting
- Adjustable leveling legs**
- SCR 8 no casters or leveling legs

NOTE: Each cabinet in a stacked unit must be configured identically. Stacking Kit 02665 shipped with order.

<input type="checkbox"/> APPROVED	<input type="checkbox"/> APPROVED AS NOTED	<input type="checkbox"/> RESUBMIT
AUTHORIZED SIGNATURE		DATE



PROJECT	ITEM NO
---------	---------

## Rotisserie

**SCR 8** 8-spit  
Countertop  
**SCR 16** 16-spit  
Stacked

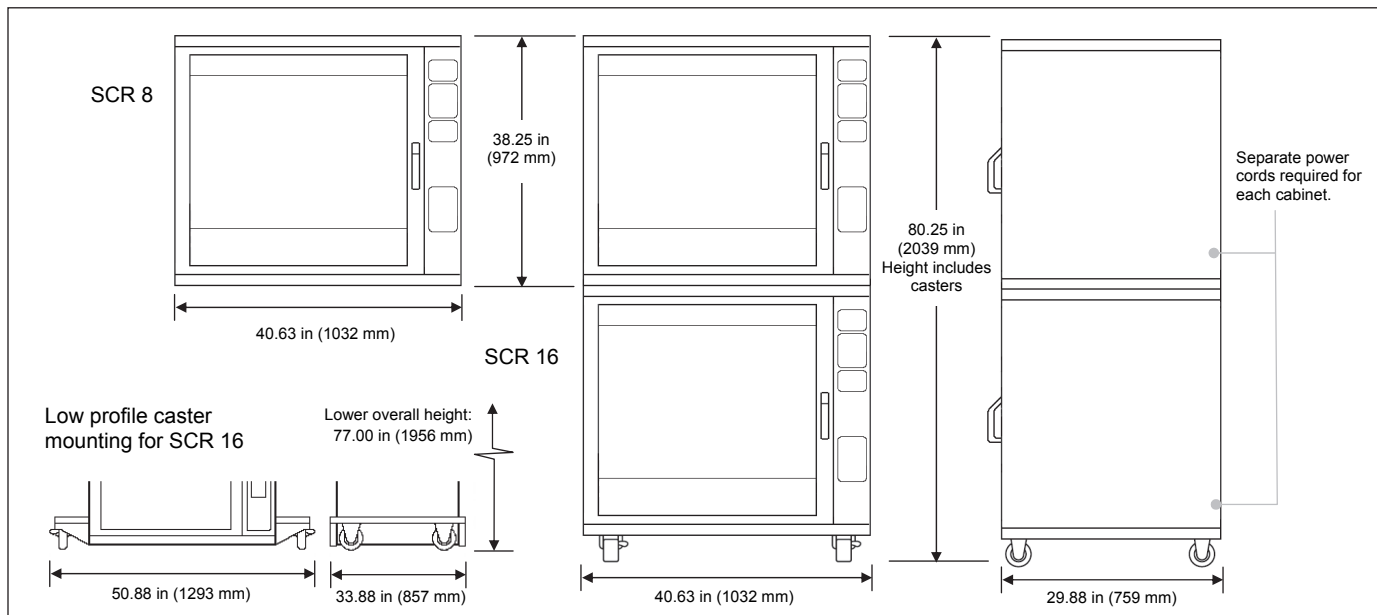

	SCR 8	SCR 16 Stacked
--	-------	----------------

### Dimensions

Height	38.25 in (972 mm)	80.25 in (2039 mm)
Width	40.63 in (1032 mm)	40.63 in (1032 mm)
Depth	29.88 in (759 mm)	29.88 in (759 mm)

### Crated

Length	48 in (1220 mm)	
Depth	37 in (940 mm)	2 crates SCR 8
Height	48 in (1220 mm)	
Volume	49.3 ft <sup>3</sup> (1.40 m <sup>3</sup> )	98.6 ft <sup>3</sup> (2.80 m <sup>3</sup> )
Weight	471 lb (214 kg)	942 lb (428 kg)

### Capacity 2.5 lb (1.1 kg) whole chickens

	8 spits	16 spits
Angled spits	32 chickens 4 per spit	64 chickens 4 per spit
Piercing spits	40 chickens 5 per spit	80 chickens 5 per spit
Basket	32 chickens 4 per spit	64 chickens 4 per spit

### Electrical

Volts	Phase	Hertz	kW	Amps	Wire
208	1	50/60	11.1	50.5	2+G
240	1	50/60	11.1	46.0	2+G
208	3	50/60	11.1	33.6	3+G
240	3	50/60	11.1	29.1	3+G
400	3	50	11.1	19.3	3NG

Power cord and plug included with 3 phase 208 V and 240 V units for USA and Canada

NEMA 15-50P

### Laboratory certifications



### Heating

Electric convection and radiant heat

### Lighting

4 tungsten halogen lamps 150 W

### Required clearances

Left	2 in (50 mm) air flow
Right	20 in (500 mm) service, power cord
Back	2 in (50 mm) air flow
	3 in (76 mm) when stacked
	28 in (711 mm) pass-through door open
Front	28 in (711 mm) door open

### Bidding Specifications

Provide Henny Penny electric rotisserie model SCR 8 countertop with 8 spit capacity or SCR 16 stacked with 16 spit capacity. When stacked to form SCR 16 both SCR 8 cabinets must be configured alike.

Unit shall incorporate:

- THERMA-VEC® Even Heat Process combines cross-flow convection heat with radiant heat
- Programmable cooking programs with programmable browning and texture settings
- Large LED displays for time and temperature
- Food probe and probe cooking capability
- Pass-through or solid back design
- Removable coated spits, rotor disks, drive tube, drip tray
- High-quality stainless steel and tempered glass
- Choice of handle and rotation switch for customer side and service side
- Choice of 8 angled or piercing spits, or baskets for each cabinet
- Choice of casters or leveling legs for single or bottom unit, or low profile casters for SCR 16

Continuing product improvement may subject specifications to change without notice.

**24 Hour Technical Support:**  
Henny Penny Technical Service  
800.417.8405  
[technicalservices@hennypenny.com](mailto:technicalservices@hennypenny.com)

**Henny Penny Corporation**  
PO Box 60 Eaton OH 45320 USA  
+1 937 456.8400 800 417.8417  
+1 937 456.8434 Fax 800 417.8434 Fax  
[www.hennypenny.com](http://www.hennypenny.com)

**HENNY PENNY**  
Engineered to Last

PROJECT	QUANTITY	ITEM NO
---------	----------	---------

# Rotisserie mobile stand

MODEL **SCT-800**



### General Information

This sturdy work table is designed specifically as a base for mounting the Henny Penny SCR-6 or SCR-8 countertop Rotisseries when built-in countertops are not available.

Henny Penny mobile rotisserie stands provide foodservice operators a safe, sanitary surface to place rotisseries while making it easy to relocate them at any time.

### Standard Features

- Sturdy, welded stainless steel frame construction.
- Four heavy-duty casters; two locking.
- Convenient lower storage shelf.

SCT-800 rotisserie work table/mobile stand

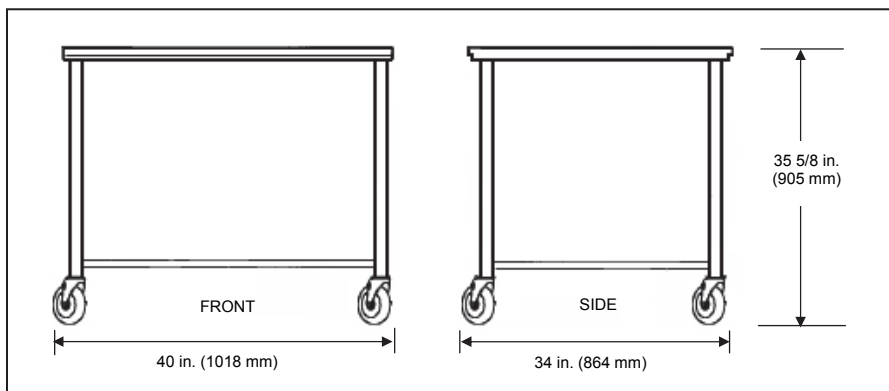

### Dimensions

Height: 35 5/8 in. (905 mm)  
 Width: 40 in. (1018 mm)  
 Depth: 34 in. (864 mm)

**Floor space:** 10 sq. ft. (1m<sup>3</sup>)

**Crated dimensions:** Contact Henny Penny

**Net weight:** N/A

**Crated weight:** Contact Henny Penny

### Bidding Specifications

- Provide Henny Penny rotisserie work table model SCT-800 and mobile stand for SCR-6 or SCR-8 countertop rotisserie.
- Unit shall be constructed of welded stainless steel and shall consist of a top surface and lower storage surface.
- Unit shall include (4) 5-inch heavy duty casters, two locking.

### Laboratory certifications



*Continuing product improvement may subject specifications to change without notice.*

<input type="checkbox"/> APPROVED	<input type="checkbox"/> APPROVED AS NOTED	<input type="checkbox"/> RESUBMIT
AUTHORIZED SIGNATURE		DATE

**Henny Penny Corporation**  
 PO Box 60 Eaton OH 45320 USA  
 +1 937 456.8400 800 417.8417  
 +1 937 456.8434 Fax 800 417.8434 Fax  
[www.hennypenny.com](http://www.hennypenny.com)

