

**HUSSMANN®**

---



Model shown with options.

---

# D5X

Excel Multi-Deck Dairy/Deli  
Display Merchandiser

## Husmann Excel Multi-Deck Display for Dairy and Deli Applications

**D5X-E D5X-LE D5X-HE D5NX-LE**  
**D5X-EP D5X-LEP D5X-HEP D5NX-LEP**

Available in 8' and 12' lengths. Contact your sales rep for information on possible availability of additional case lengths.

**E = Energy Efficient Coil**  
**EP = E Plus, Extra High Efficiency Coil**

**L = Low Front**  
**H = High Front**  
**N=Narrow Footprint**

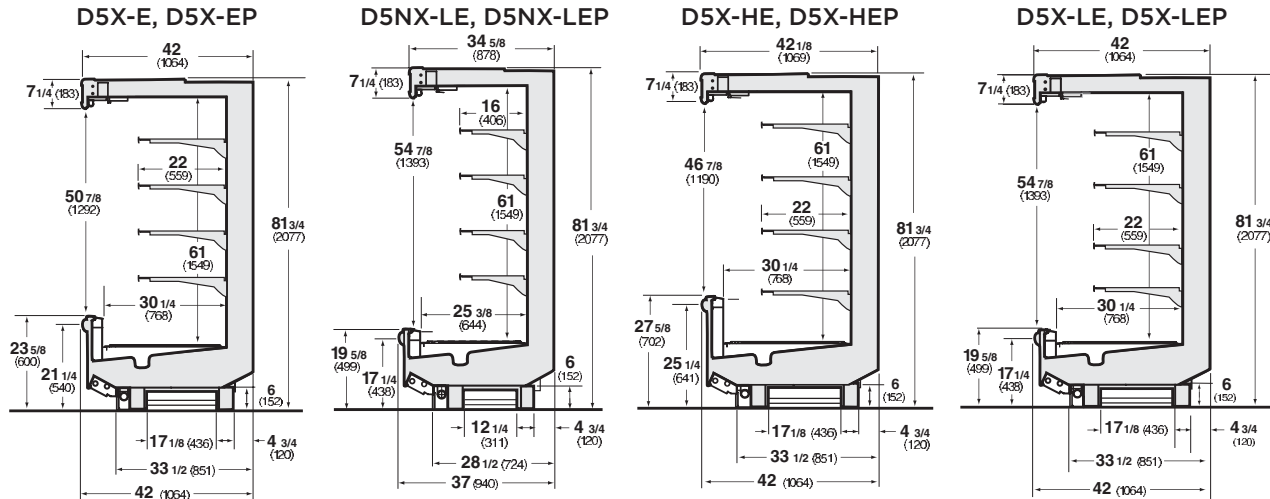

**Plan View -**  
**D5X-E, D5X-LE, D5X-LEP, D5X-HE, D5X-HEP**

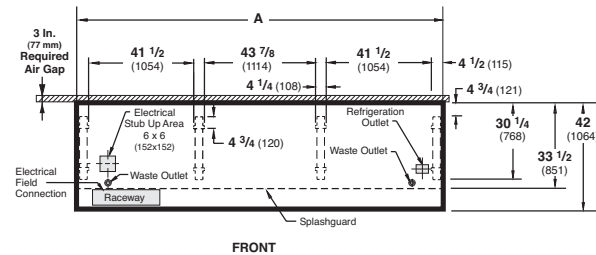

Dimension	8 FT	12 FT
A	96 3/8 (2448)	144 1/2 (3670)

**Notes:**  
 Case-to-case electrical connections are made in front of splashguard.  
 Overall case length without ends or partitions.

### Note

Use Husmann's technical data sheets to get precise dimensions for all store layout purposes.

### Superior Merchandising.

The D5X family was designed to help you merchandise and sell. Superior display features include full vision glass ends, illuminated canopy signs, improved ledge lighting, greater shelf placement flexibility and more. Streamline and contour styling available.

### Lower Energy Costs.

Excel D5X cases come with energy efficient "E" coils as standard on "E" models. The super efficient E-Plus coils on "EP" models reduce energy costs by about 18% compared to standard Impact dairy. Night curtains can be added to help trim about 12.6% more off your energy costs for this case.

**Plan View -**  
**D5NX-LE, D5NX-LEP**

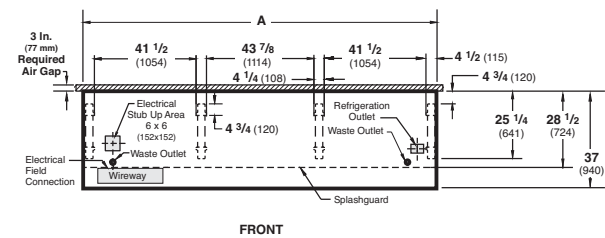

Dimension	8 FT	12 FT
A	96 3/8 (2448)	144 1/2 (3670)

**Notes:**  
 Case-to-case electrical connections are made in front of splashguard.  
 Overall case length without ends or partitions.

### Superior Shelf Life.

Modular coils and off-time defrost work to reduce thermal shock and stabilize product temperatures. Modular defrost (optional) can further stabilize temperatures.

**DOE 2012 Energy Efficiency Compliant** Husmann refrigerated merchandisers configured for sale for use in the United States meet or surpass the requirements of the DOE 2012 energy efficiency standards.

NOTE: These merchandisers are designed for use in stores when temperature and humidity do not exceed 75°F and 55% R.H.

NOTE: We reserve the right to change or revise specifications and product design in connection with any feature of our products. Such changes do not entitle the buyer to corresponding changes, improvements, additions, or replacements for equipment previously sold or shipped.

For additional resources, contact your representative or visit [www.husmann.com](http://www.husmann.com).

# HUSMANN®

**Husmann Corporation**  
 12999 St. Charles Rock Rd.  
 Bridgeton, MO 63044-2483  
 Ph: 314.291.2000

[www.husmann.com](http://www.husmann.com)